

EN



autoterm

# Relay set 12V for Flow 5

## User's manual

**Manufacturer: AUTOTERM LLC**

Paleju 72, Marupe, Latvia, LV-2167

**Warranty Department** [warranty@autoterm.com](mailto:warranty@autoterm.com)

**Technical Support** [service@autoterm.com](mailto:service@autoterm.com)

[www.autoterm.com](http://www.autoterm.com)

The set of relay is designated for connection of the heating device AUTOTERM Flow 5 to the heater of the saloon of the car. During the operation process of the heating device, when the temperature of liquid reaches the set value (see the manual of operation for the control panel AUTOTERM Comfort Control), the relay is activated and switches on the fan of the heater of the car saloon (provided that the switch of the fan of car saloon is switched on). In order to connect the set of relay to the cord of the heating device, one has to take off the insulation from the ends of wires to be connected, put on the wire the thermo-contractible tube and wind together the wires of the same colour, then solder the wound wires. Install the thermo-contractible tube so that the winding (soldered place) is in the middle of the tube. Heat up the tube and put it on the wires.

**Attention! It is prohibited to use a non-soldered connection.**

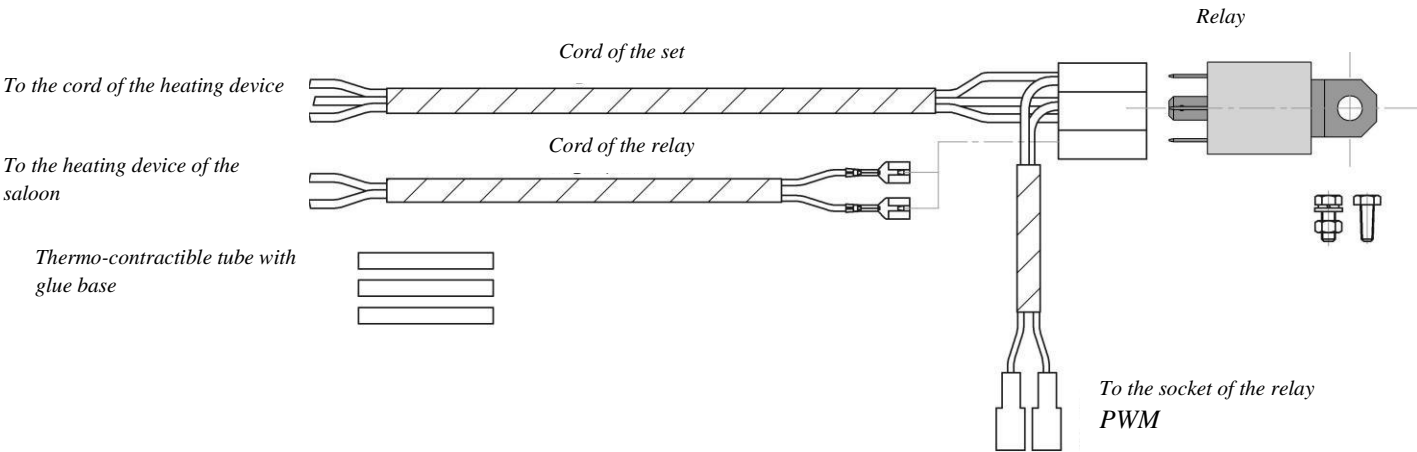

To perform further connection according to the circuit of electrical connections

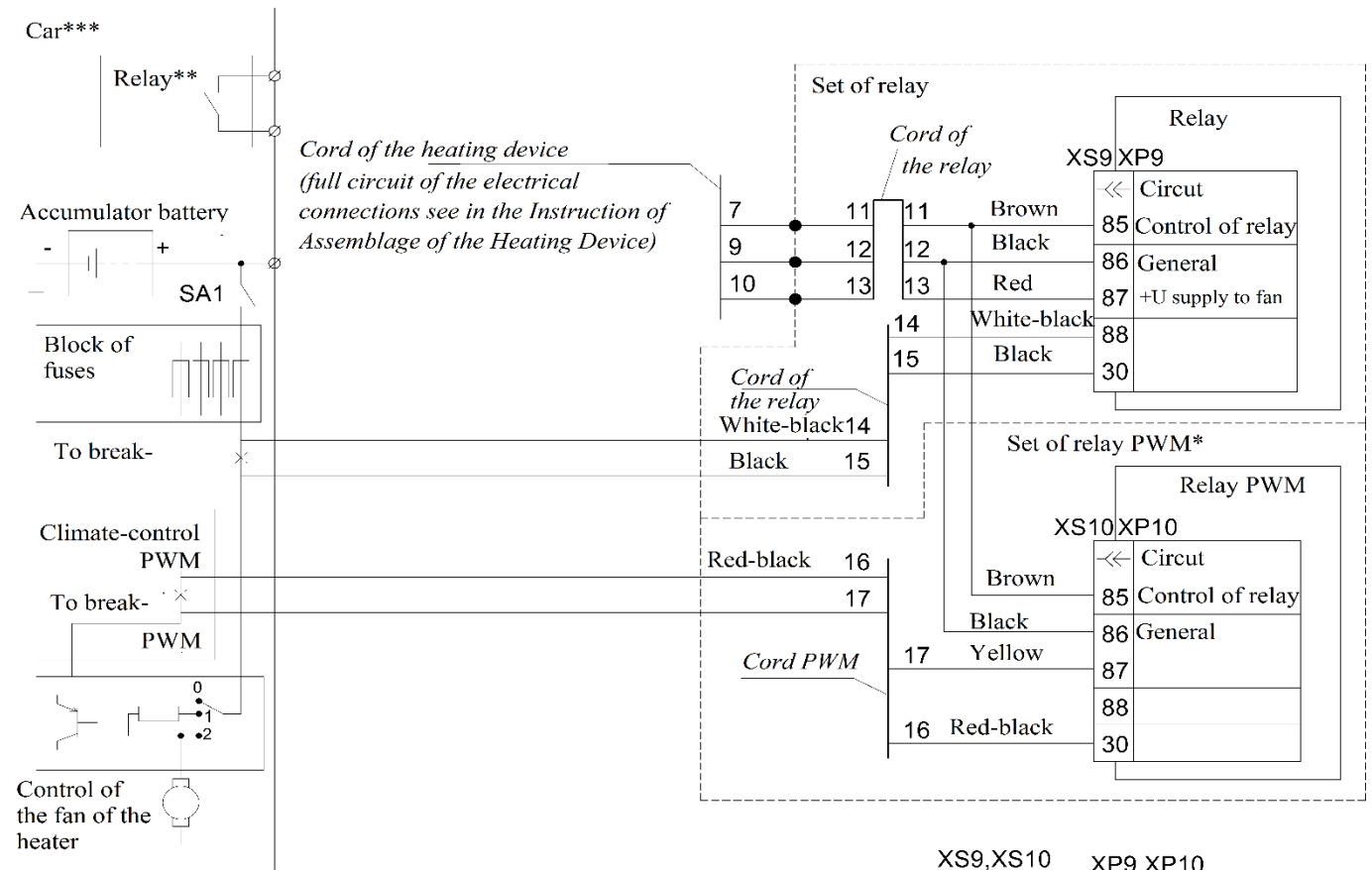

- 1 \* Upon an additional order.
- 2 \*\* Relay which is installed by the remote alarm system.
- 3 \*\*\* Example of connection of the heating device to the car.

